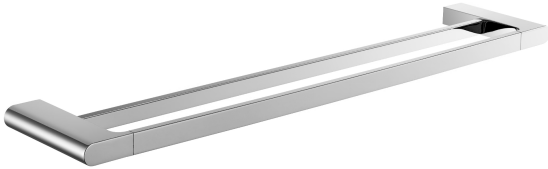
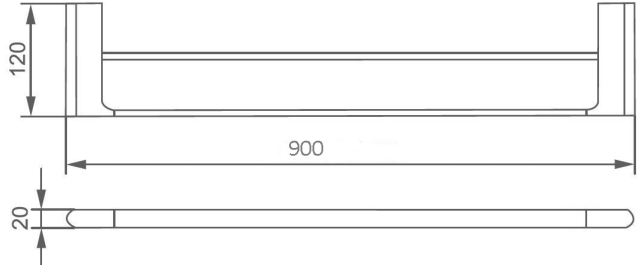

Sync Double Towel Rail 900mm

Product Image	Technical Specification
 <p>*Chrome pictured</p>	

Description	Attributes						
<p>Sync Double Towel Rail 900mm</p> <table border="0"> <tr> <td>YS1120</td> <td>Chrome</td> </tr> <tr> <td>YS11201</td> <td>Matte Black</td> </tr> <tr> <td>YS11202</td> <td>Brushed Nickel</td> </tr> </table>	YS1120	Chrome	YS11201	Matte Black	YS11202	Brushed Nickel	<ul style="list-style-type: none"> • Made from top quality brass • Warranty : 7/1 years
YS1120	Chrome						
YS11201	Matte Black						
YS11202	Brushed Nickel						

*All dimensions are in millimeters and are subject to normal manufacturing variations. Actual dimensions should be checked prior to installation. Yushi pursues a policy of continuing improvement in design and performance of its products. The right is therefore reserved to vary specifications without notice.